



INSTALLATION GUIDE

Thank you for choosing a B-PWR product, designed by passionate riders who focus on what users really need.

1. SAFETY INSTRUCTIONS

To avoid any unfortunate situations, we recommend that you get to know how your modified vehicle handles before using it in extreme conditions.

Read all the instructions carefully before installing this product.

If you do not have the tools or technical knowledge needed to ensure proper installation, have the product installed by an authorized dealer.

⚠ WARNING

It is essential that you follow the installation procedures, possess general mechanical knowledge and use appropriate tools to ensure a safe and reliable installation.

Improper use or installation of the product, or any modifications made to adapt the product for use in a context other than that for which it was intended, voids the warranty and may result in **SERIOUS INJURIES**.

B-PWR and all its affiliated companies, as well as its suppliers and distributors, are not responsible for any consequences whatsoever resulting from an incorrect installation or an improper use of the product.

This guide provides detailed instructions for installing the product.

AVAILABLE KIT

SG5FB-HD

COMPATIBILITY

Ski-Doo Gen 5 / Gen 4

⚠ WARNING

For safety reasons, this kit needs to be installed by a person with general mechanical knowledge using the proper tools.

The illustrations in this document indicate the typical structure of the various assemblies. It is therefore possible that they do not represent the exact form of the parts or the manufacturing details. These illustrations are intended to identify parts that perform an identical or similar function.

2. PARTS

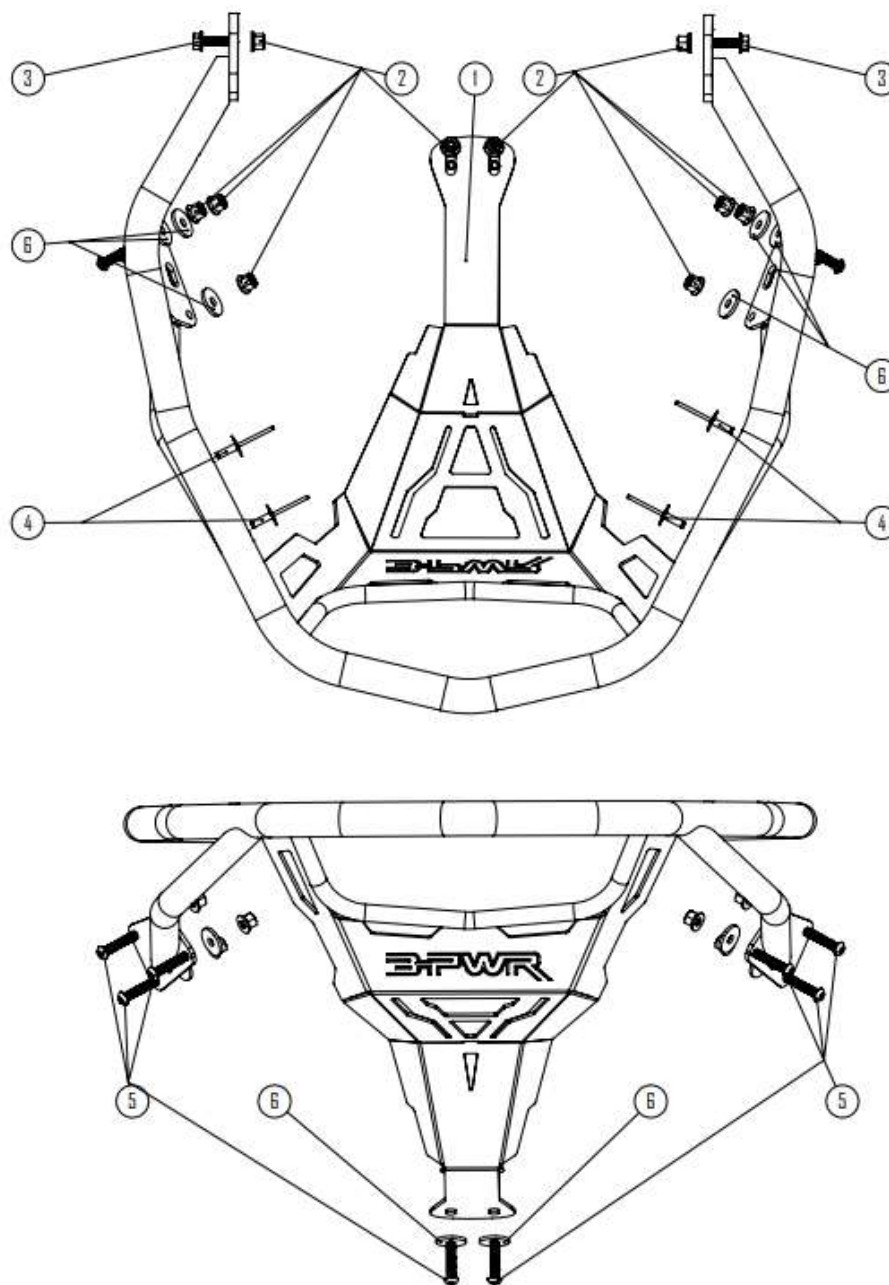

PART	DESCRIPTION	QTY	PART NUMBER
P1	FRONT BUMPER G5	1	10-0000
P2	LOCK NUT M6	10	K05-SG5FB-HD
P3	HEX HEAD SCREW M6 X 20 mm	2	
P4	RIVET 3/16"	4	
P5	SCREW M6 X 20 mm	8	
P6	WASHER M6	8	

3. PREPARATION OF THE VEHICLE

- 3.1 Read all instructions carefully before installing this product.
- 3.2 Make sure you have enough space to work well.
- 3.3 Make sure you have all the required tools.
- 3.4 Refer to vehicle owner's manual for removal of various panels and other parts.

4. INSTRUCTIONS

- 4.1 Remove the side panels, the top panels and the silencer. Consult the owner's manual for this step.



- 4.2 Remove the existing bumper. Drill the rivets using a 3/8" dia drill bit. Take the necessary precautions to avoid damaging the plastic of the bodywork.

4.3 Install the G5 front bumper [P1] with two (2) M6 X 20mm hex shoulder screws [P3] and M6 self-locking nuts [P2]. Hand tighten only.



4.4 Position the bumper in order to obtain an optimal adjustment of the side plates with the bodywork.



4.5 Secure the G5 front bumper [P1] with four (4) 3/16" rivets [P4] using a hand riveter.



4.6 Meter in place the bracket for the muffler temperature switch.



4.7 Tighten to the specified torque two (2) M6 self-locking nuts [P2],



TORQUE	
LOCK NUT [P2]	10 N•m ± 2 N•m

4.8 Drill the hull of the snowmobile through the holes in the side plates of the G5 bumper [P1] with a 3/16" drill bit. Secure using M6x20 screws [P5], washers [P6] and nuts [P2].



TORQUE	
LOCK NUT [P2]	10 N•m ± 2 N•m

4.9 Drill two (2) holes under the vehicle using the G5 front bumper [P1] as a template using a 3/16" drill bit. Secure using M6x20 screws [P5], washers [P6] and nuts [P2].



TORQUE	
LOCK NUT [P2]	10 N•m ± 2 N•m

4.10 Reinstall the muffler and various panels by reversing the removal steps. Refer to owner's manual.
Note: Be sure to reconnect the connectors to the center panel.