



INSTALLATION GUIDE

Thank you for choosing a B-PWR product, designed by passionate riders who focus on what users really need.

1. SAFETY INSTRUCTIONS

To avoid any unfortunate situations, we recommend that you get to know how your modified vehicle handles before using it in extreme conditions.

Read all the instructions carefully before installing this product.

If you do not have the tools or technical knowledge needed to ensure proper installation, have the product installed by an authorized dealer.

⚠ WARNING

It is essential that you follow the installation procedures, possess general mechanical knowledge and use appropriate tools to ensure a safe and reliable installation.

Improper use or installation of the product, or any modifications made to adapt the product for use in a context other than that for which it was intended, voids the warranty and may result in **SERIOUS INJURIES**.

B-PWR and all its affiliated companies, as well as its suppliers and distributors, are not responsible for any consequences whatsoever resulting from an incorrect installation or an improper use of the product.

This guide provides detailed instructions for installing the product.

AVAILABLE KIT

RBG4-LYNX-3900, RBG4-LYNX-4100

COMPATIBILITY

Lynx platform G4

⚠ WARNING

For safety reasons, this kit needs to be installed by a person with general mechanical knowledge using the proper tools.

The illustrations in this document indicate the typical structure of the various assemblies. It is therefore possible that they do not represent the exact form of the parts or the manufacturing details. These illustrations are intended to identify parts that perform an identical or similar function.

2. PARTS– RBG4-LYNX-3900

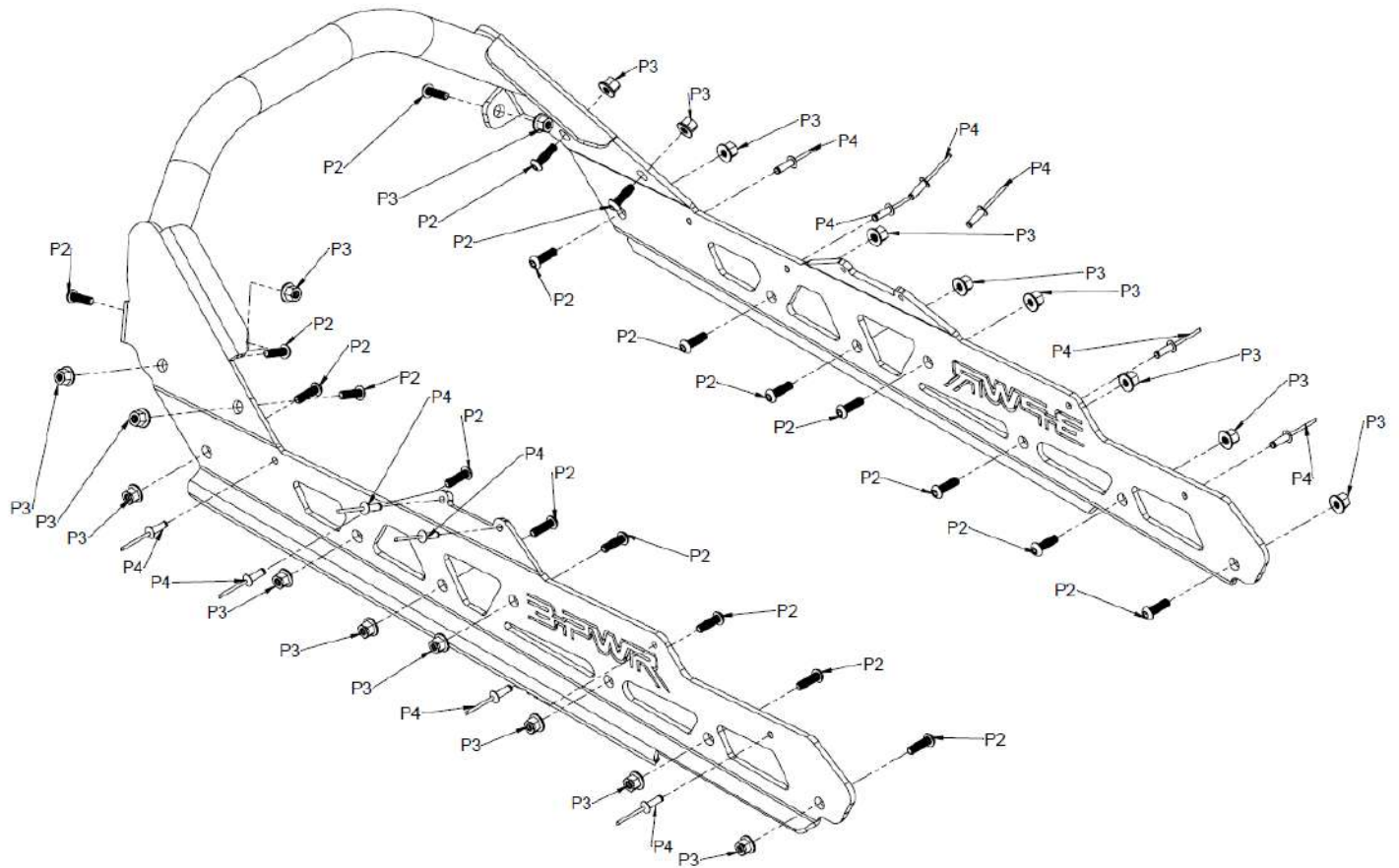

PIECE	DESCRIPTION	QTY	PARTS NUMBERS
P1	Rear bumper	1	
P2	Socket head bolt M6-1,0 X 20mm	20	K05-RBSG4-LYNX
P3	M6-1.0 hexagonal nylon lock nut	20	
P4	Blind rivet AB6-6A, 3/16 diameter, thickness ,250- ,375	14	

RBG4-LYNX-4100

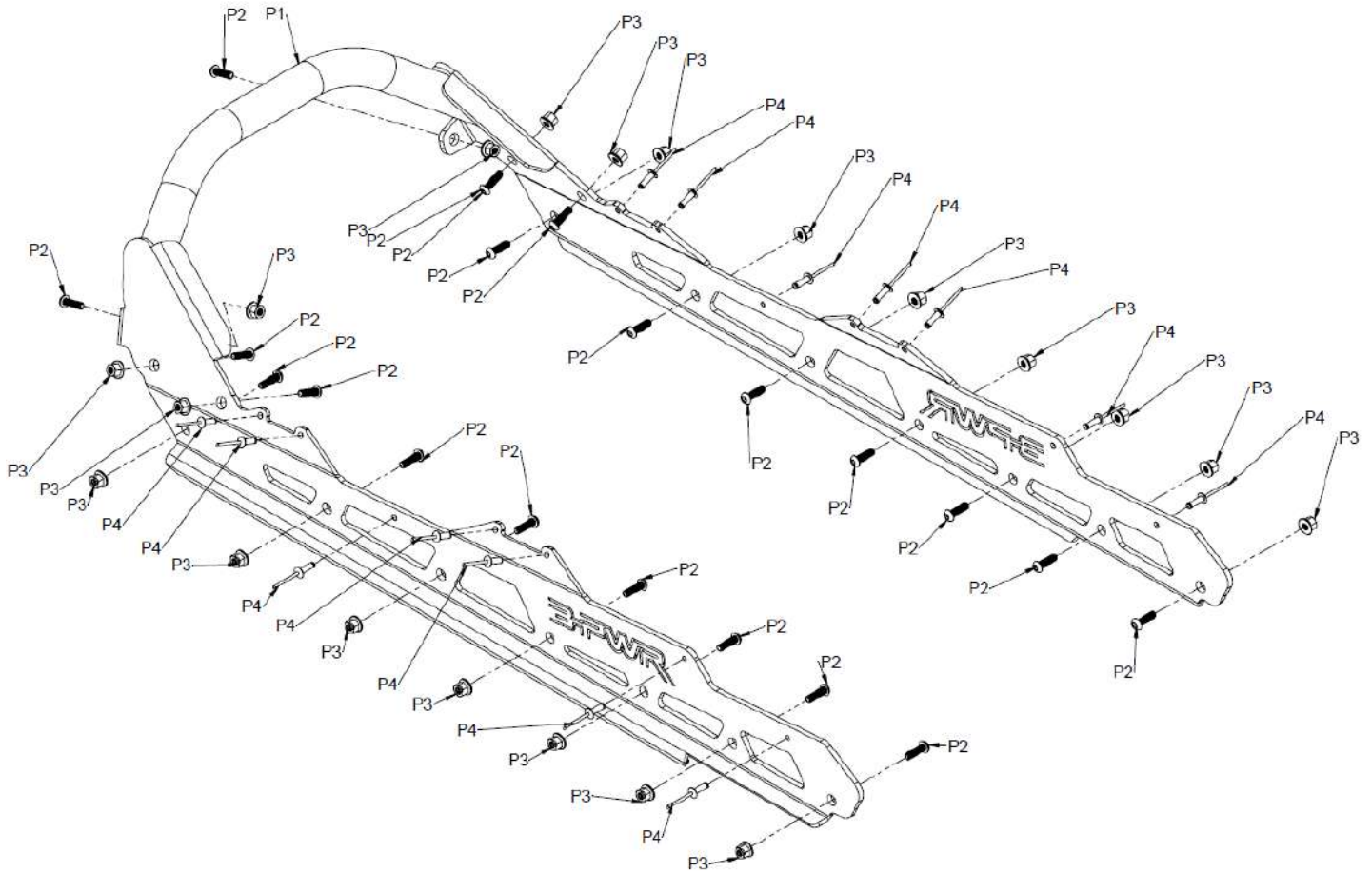

PIECE	DESCRIPTION	QTY	PARTS NUMBERS
P1	Rear bumper	1	
P2	Socket head bolt M6-1,0 X 20mm	20	K05-RBSG4-LYNX
P3	M6-1.0 hexagonal nylon lock nut	20	
P4	Blind rivet AB6-6A, 3/16 diameter, thickness ,250-,375	14	

3. VEHICLE PREPARATION

- 3.1 Read all the instructions carefully before installing the product.
- 3.2 Make sure you have enough space to work properly.
- 3.3 Make sure to have the required tools.
- 3.4 Refer to vehicle owner's manual for removal of various panels and other parts.

4. INSTRUCTIONS

Note: Unless differences occur between left hand (LH) and right hand (RH) sides, the procedures are shown for only one side of the vehicle. Repeat for other side. Right and left sides are defined as when sitting on the vehicle.

- 4.1 Slide rear bumper [P1] in position on vehicle as shown.

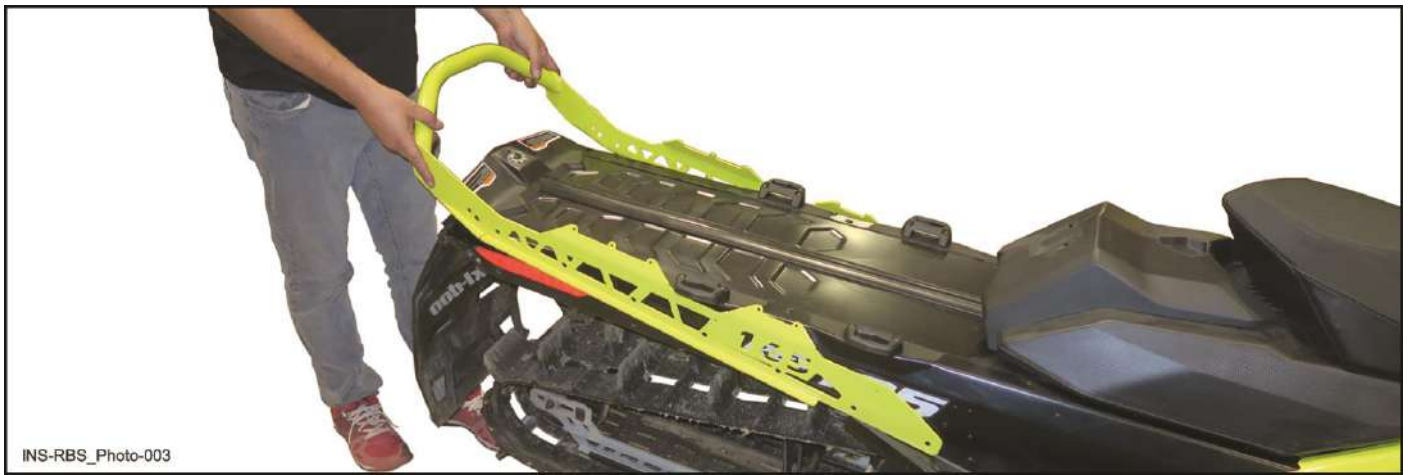

- 5.2 Install rear bumper [P1] with Socket head bolt M6-1,0 X 20mm [P2] M6 nylon lock nut [P4].

Note : Use holes already present in tunnel.



5.3 Tighten to specification M6 nylon lock nut [P3].



TIGHTENING TORQUE	
M6 Nylon Lock Nut [P3]	10 N•m ± 2 N•m

5.4 Drill eight rivet holes in tunnel using bumper as a template with drill bit 3/16" as shown.



5.5 Secure bumper with 3/16" rivet [P5] in previously drilled holes as shown.

