



INSTALLATION GUIDE

Thank you for choosing a B-PWR product, designed by passionate riders who focus on what users really need.

1. SAFETY INSTRUCTIONS

To avoid any unfortunate situations, we recommend that you get to know how your modified vehicle handles before using it in extreme conditions.

Read all the instructions carefully before installing this product.

If you do not have the tools or technical knowledge needed to ensure proper installation, have the product installed by an authorized dealer.

⚠ WARNING

It is essential that you follow the installation procedures, possess general mechanical knowledge and use appropriate tools to ensure a safe and reliable installation.

Improper use or installation of the product, or any modifications made to adapt the product for use in a context other than that for which it was intended, voids the warranty and may result in **SERIOUS INJURIES**.

B-PWR and all its affiliated companies, as well as its suppliers and distributors, are not responsible for any consequences whatsoever resulting from an incorrect installation or an improper use of the product.

This guide provides detailed instructions for installing the product.

AVAILABLE KIT

ATC-G5EXP

COMPATIBILITY

B-PWR bumpers: RBEXP-154 & RBEXP-165

⚠ WARNING

For safety reasons, this kit needs to be installed by a person with general mechanical knowledge using the proper tools.

The illustrations in this document indicate the typical structure of the various assemblies. It is therefore possible that they do not represent the exact form of the parts or the manufacturing details. These illustrations are intended to identify parts that perform an identical or similar function.

2. PARTS

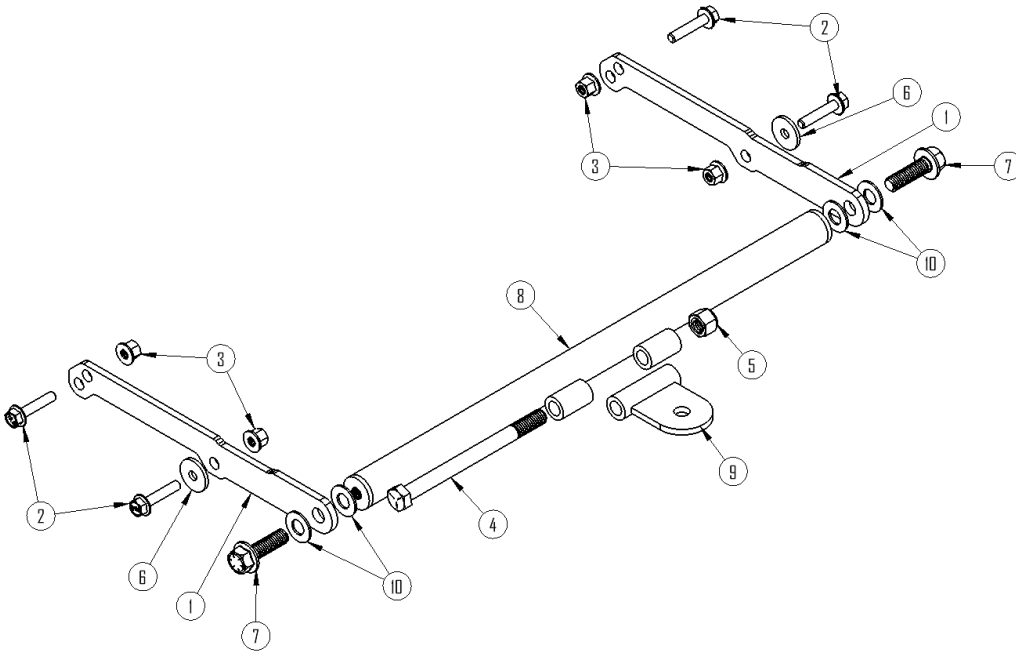

PART	DESCRIPTION	QTY	PART NUMBER
P1	Side support plate	2	11-2016
P2	Bolt	4	K05-ATC-EXP
P3	Locknut	4	
P4	Bolt	1	
P5	Lock nut	1	
P6	Washer	4	
P7	Bolt	2	
P8	Tube with bolt	1	11-0005
P9	Tongue	1	11-0007
P10	Washer	4	K05-ATC-EXP

3. VEHICLE PREPARATION

- 3.1 Read all the instructions carefully before installing the product.
- 3.2 Make sure you have enough space to work properly.
- 3.3 Make sure to have the required tools.
- 3.4 Refer to vehicle owner's manual for removal of various panels and other parts.

4. INSTRUCTIONS

- 4.1 Remove the last B-PWR rear bumper screw as shown in the photo.



- 4.32 Using the B-PWR bumper rivet hole as a guide, drill the tunnel with a 9/32" drill.



4.3 Insert screws [P2].



4.4 Inside the tunnel, insert the washer [P6] on the screw [P2] furthest back of the tunnel.



4.5 Insert the lateral support plate [P1] on the screws [P2]. Insert the nuts [P3] on the screws [P2]. Tighten to the specified torque.

TORQUE	
12 Lbs* π \pm 2 lbs* π	16 N•m \pm 3 N•m



4.6 Repeat steps 4.1 to 4.5 on the other side.

4.1 Install the tongue [P9] on the tube [P8] with the screw [P4] and the nut [P5]. Screw the first threads by hand. Torque to specified torque.

TORQUE	
12 Lbs* π \pm 2 lbs* π	16 N•m \pm 3 N•m



4.8 Be sure to install a washer [P10] on each side of the side support plate [P1], screw the screw [P7] by hand to the tube [P8]. Repeat on the other side.



4.9. Position the tube at the height and torque to the specified torque.

TORQUE	
22 Lbs* π \pm 3 lbs* π	30 N•m \pm 4 N•m

Commenté [PG1]: @Karyn Lebrun anglais corrigé! Good to go



4.10. End of Installation.